

CONTROL STRATEGY FOR LOAD SHARING OF PARALLELED INVERTER IN ISLANDED MODE

P C TEJASVILAXMAN BHATTAR^{1a} AND M. KOWSALYA^b

^{ab}Department of Electrical Engg. VIT, Vellore

ABSTRACT

Distributed energy system with renewable energy sources have made necessary to operate the power inverters in parallel for load sharing and reliability. Simple control strategy using droop controller with current and voltage regulating loop was developed. Control schemes with less complexity and computation has been proposed and developed for enhancing the power sharing capability and limiting the circulating current in parallel operated inverter.

Keywords: Distributed energy system, Parallel inverters, Synchronization, Droop control, Load sharing

Growing energy demand has forced the development of micro-grid technology. The integration of various renewable energy resources for efficient energy harvesting is key objective of micro-grid technology. In AC micro grid systems, inverters needs to be operated in parallel with high reliability due to the penetration of renewable energy sources (wind, solar etc) in the system. The Wind, Solar and fuel cells are driving forces for micro-grid.

Micro-grids can be operated in islanded or grid connected mode depending upon power demands and they have gained the popularity as back up grid during peak demand and grid support for week grids.

Micro-grid system reliability and power capacity is obtained by paralleling the available sources with power converters. Operating parallel sources with suitable power converter along with effective control strategy is required to overcome various control problems. Due to wide variation of renewable energy sources, control problem for operating units of power converters in micro grids includes power sharing, effective current distribution and power quality. Novel control strategies were adopted to deal with control problem power converter. Control strategy was developed for efficient parallel operation of inverter to share the power accurately and to avoid the circulating current. The slow and poor transient response of conventional droop controller was improved by introducing the derivative and integral term. The advances in control strategies include the wireless controller for load sharing [1]. The accurate power sharing is affected by the output impedance of inverter.

To have good power sharing, the controller with adaptive output impedance loop has been proposed [2]. The other approach was to force the output impedance as resistive so as to achieve harmonic sharing and power sharing to obtain good dynamic response[3]. Low frequency drift affects the stability for accurate power sharing; the adaptive decentralized droop controller maintains the reliability and forces the micro-grid in stable operation [4]. An autonomous controller which uses the power angle droop was developed to reduce the power swing and to obtain the desired sharing of power [5]. Accurate power control technique was designed to control the active and reactive power where the system was introduced with virtual inductance as proposed algorithm was implemented successfully for grid connected as well as islanded mode of operation [6]. Proportional Resonant controller has overtaken then conventional proportional-integral-derivative control in terms of dynamic response [7]. Proportional-multi-resonant controller was proposed in order to have better power sharing instead of output impedance mismatch and voltage unbalance [8]. Non-linear load needs the reactive power sharing, Hierarchical Controller was designed to share the non-fundamental power[9]. The droop structure varies with output impedance a robust controller was designed to act a universal droop controller [10]. The novel robust Droop controller was developed drifts, numerical errors and the mismatch. The further advancement was to utilize the zero gain property to develop effective control techniques. Bounded droop controller with robust nature was developed [11].

The novel contributions in this paper are 1) Utilization of current and voltage control loop with simple conventional droop schemes. 2) Enhancing the power sharing capability for parallel operated inverter with reduced impact of circulating current by using simple control strategy.

PARALLEL OPERATION OF INVERTER IN MICROGRID SYSTEM

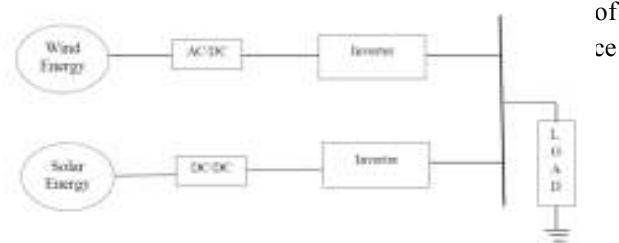

Fig.1: Micro-grid Structure in Islanded Mode

The Micro-sources like wind, solar, Fuel cell and battery technology comprises the micro-grid power generation system. System with wind and Solar is depicted in Fig.1, represents the small micro-grid system.

Wind Energy

Wind energy is harvested using induction generator. The output of induction generator is fed to ac to dc converter which maintain the dc link voltage for inverter. The output power of inverter is utilized in islanded mode of operation.

Solar Energy

The solar energy is harvested by using the appropriate MPPT technique with suitable DC-DC converter. The DC-DC converter provides the dc link voltage for inverter.

The adopted system consists of two parallel operating inverter with tie-line shown in Fig.2 [12]. DC link sources are derived from wind and solar

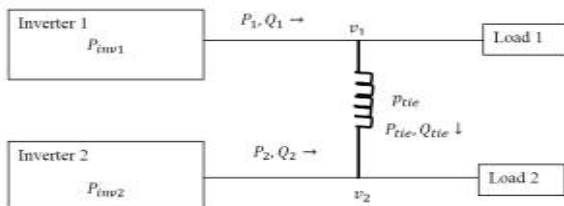

Fig.2 :Two parallel operating inverter with tie-line

PROPOSED CONTROL SCHEME

Key operating idea of Droop Controller is a motivated by Parallel operation of Alternators [13, 14]. The control scheme for islanded mode of operation has been developed to share the accurate power for reliable operation in power inverters. Individual control strategy for inverter was designed to perform parallel operation. The simple control strategy uses the traditional droop for voltage and current reference generation. The compensator is designed for current loop to provide the stability and to achieve the fast response. The proportional controller in outer loop is designed for better voltage regulation. The controller with less computation and reduced complexity has been proposed.

Inverter Model

The H bridge inverter Fig.3 with input 120 V and the output of 84 V rms is designed which feeds the RL load and bridge rectifier load. It uses the simple switching sequence T₁, T₄ is on and the T₂, T₃ is off, the simple SPWM technique is used. Inductor L_f and capacitor C_f denotes the output filter. The load is represented by the Z. The dynamic model of single phase full bridge PWM inverter is obtained by using state space analysis [15].

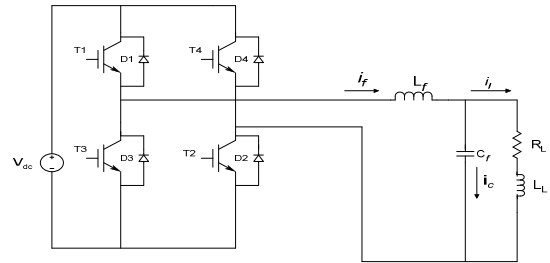

Fig.3: Layout of H-Bridge Inverter

The following equation describes the dynamic model of inverter. U(t) is switching function.

$$\begin{bmatrix} \dot{i}_f \\ \dot{v}_c \\ \dot{i}_l \end{bmatrix} = \begin{bmatrix} 0 & 0 & -\frac{1}{L_f} \\ \frac{1}{C_f} & -\frac{1}{C_f} & 0 \\ \frac{1}{L_l} & -\frac{R_l}{L_l} & 0 \end{bmatrix} \begin{bmatrix} i_f \\ i_l \\ v_c \end{bmatrix} + \begin{bmatrix} \frac{1}{L_f} \\ \frac{1}{C_f} \\ 0 \end{bmatrix} V_t * U(t) \quad (1)$$

$$V_0 = \begin{bmatrix} 0 & 0 & 1 \end{bmatrix} \begin{bmatrix} \dot{i}_f \\ i_l \\ v_c \end{bmatrix} \quad (2)$$

State Space Average Model of Inverter: Assumption

Switching losses, conduction losses are neglected. Switches are considered to be ideal [16,17]

i) Mode 1 (ON time)

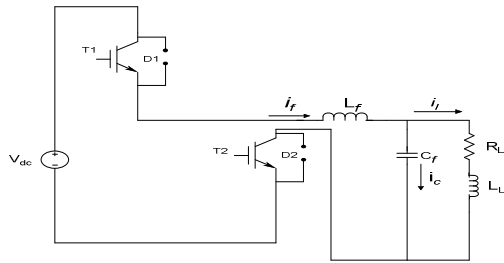

Fig.4 :Conducting State for T₁ and T₂

Switches T₁ and T₂ conducts. The equivalent circuit diagram is shown in Fig .4. The state space model during ON time is obtained. ON time is represented for DT interval of time where D is duty

$$\begin{bmatrix} \dot{i}_f \\ \dot{v}_c \\ \dot{i}_L \end{bmatrix} = \begin{bmatrix} 0 & -\frac{1}{L_f} & 0 \\ \frac{1}{C_f} & 0 & -\frac{1}{C_f} \\ 0 & \frac{1}{L_f} & -\frac{R_L}{L_f} \end{bmatrix} \begin{bmatrix} i_f \\ v_c \\ i_L \end{bmatrix} + \begin{bmatrix} \frac{1}{L_f} \\ 0 \\ 0 \end{bmatrix} V_{dc} \quad (3)$$

i) Mode 2 (OFF time)

Switch T₁ turns off. The Diode D₃ conducts. The equivalent circuit diagram is shown in Fig .5. The OFF time can be represented by (1 - D)T interval of time.

The state space model for off time is given as

$$\begin{bmatrix} \dot{i}_f \\ \dot{v}_c \\ \dot{i}_L \end{bmatrix} = \begin{bmatrix} 0 & -\frac{1}{L_f} & 0 \\ \frac{1}{C_f} & 0 & -\frac{1}{C_f} \\ 0 & \frac{1}{L_f} & -\frac{R_L}{L_f} \end{bmatrix} \begin{bmatrix} i_f \\ v_c \\ i_L \end{bmatrix} + \begin{bmatrix} 0 \\ 0 \\ 0 \end{bmatrix} V_{dc} \quad (4)$$

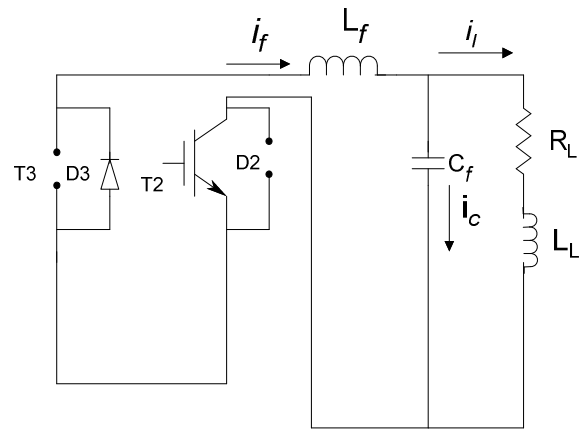

Fig.5 :Conducting State whenT₁ goes Off and D₃ comes in action

The system equation can be generalized as

$$\dot{x} = Ax + Bu$$

The ON time and OFF time state space vector matrix can be obtained.

The average DC model for steady state analysis is obtained using equation (3), (4)

$$\begin{bmatrix} 0 \\ 0 \\ 0 \end{bmatrix} = \begin{bmatrix} 0 & -1 & 0 \\ 1 & 0 & -1 \\ 0 & -1 & -R_L \end{bmatrix} \begin{bmatrix} i_f \\ v_c \\ i_L \end{bmatrix} + \begin{bmatrix} D \\ 0 \\ 0 \end{bmatrix} V_{dc} \quad (5)$$

Small signal AC model of inverter is obtained by perturbation and linearization

$$\begin{bmatrix} \hat{i}_f \\ \hat{v}_c \\ \hat{i}_L \end{bmatrix} = \begin{bmatrix} 0 & -\frac{1}{L_f} & 0 \\ \frac{1}{C_f} & 0 & -\frac{1}{C_f} \\ 0 & \frac{1}{L_f} & -\frac{R_L}{L_f} \end{bmatrix} \begin{bmatrix} \hat{i}_f \\ \hat{v}_c \\ \hat{i}_L \end{bmatrix} + \begin{bmatrix} \frac{D}{L_f} \\ 0 \\ 0 \end{bmatrix} \hat{V}_{dc} + \begin{bmatrix} \frac{V_{dc}}{L_f} \\ 0 \\ 0 \end{bmatrix} \hat{d} \quad (6)$$

Control Diagram

The control diagram for single unit of inverter is shown in Fig.6. The control diagram represents the mathematical model of inverter and control structure including current and voltage regulation. The inner current loop was designed to achieve fast response by sensing the capacitor current [18, 19]. The outer voltage control loop was adapted to achieve the desired output response. Transfer function was derived by using equation 6.

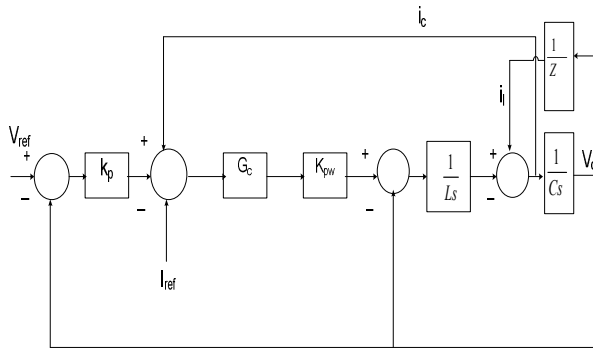

Fig.6 :Represents the control diagram for single unit inverter

Droop Controller

The reference voltage signal was generated by using traditional droop. Fig.7 shows the basic layout of droop controller. The power block calculates the active and reactive power. The droop was implemented and droop coefficients were selected to generate the reference voltage.

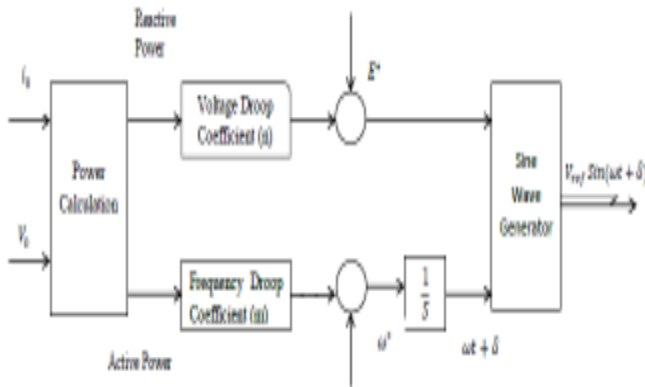

Fig.7 :Traditional Droop Control Schemes for Reference Generation

SIMULATION RESULTS

The parallel operated inverter was simulated in Matlab environment. Independent control scheme was developed for each inverter. The following parameters for parallel operation of inverter are considered for simulation environment.

For Single Inverter

The system with controller has 0.06% of voltage THD and 0.08% Of current THD. The system produces negligible distortion with linear load. The

voltage and current wave form is shown as in Fig.8 for resistive Load. The current follows with voltage for resistive load maintaining unity power factor.

TABLE I.DESIGN PARAMETERS

L_{fL}	700 μ H
L_{fZ}	700 μ H
C_{fL}	20 μ F
C_{fZ}	20 μ F
n	2.84
m	0.02
switching frequency	15kHz
frequency	60Hz
Load impedance 1	12 ohms
Load impedance 2	12+j0.3768 ohms L=1mH
Tie-line	1.7mH
Current Loop	$K_p=0.2, K_i=10$
Voltage Loop	$K_p=500$
Output Voltage V_0	84 V r.m.s Volts

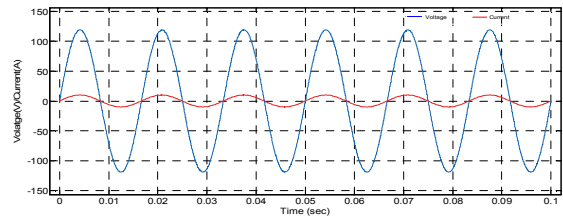

Fig.8 :Voltage and Current waveform for Resistive Load

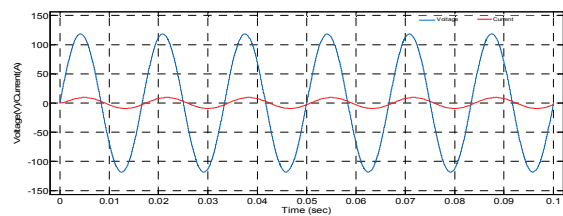

Fig.9.1 :Voltage and current waveform for inductive Load

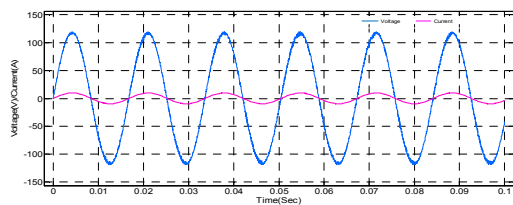

Fig.9.2: Voltage and current waveform for inductive Load

Fig.9.1 depicts the nature voltage and current for inductive load with voltage compensator. In absence of current compensating loop, the current fails to track the voltage waveform. The system fails to achieve unity power factor in absence of inner loop. The system is incorporated with current compensator loop along with voltage compensator loop. The current tracks the voltage in presence of inner loop as shown in Fig.9.2, making the system to achieve the unity power factor. Fig 10.1, Fig.10.2, Fig.10.3 shows the step change in load. The step change of 2 ohms was made at every 3ms. The current and voltage waveforms are observed. Step change has negligible voltage transients.

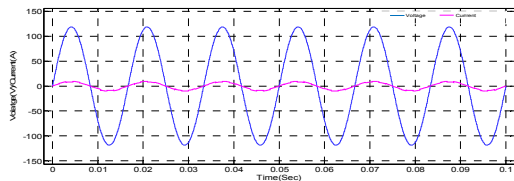

Fig.10.1: Voltage and current Waveform for Step Change in load

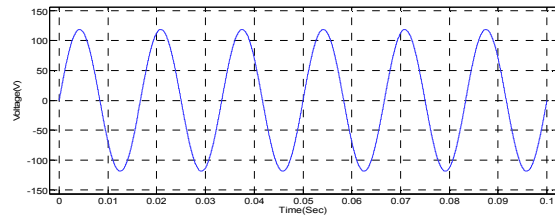

Fig.10.2: Voltage Waveform during Step Change in load

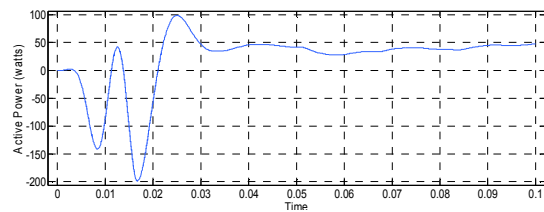

Fig.11.1: Active power loading for Inverter 1

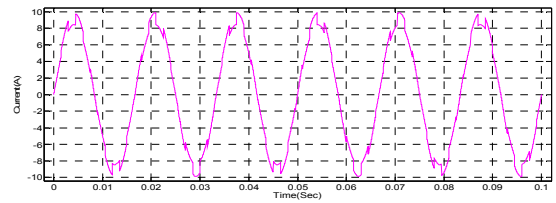
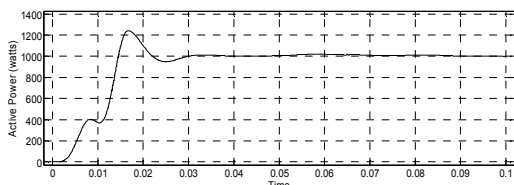

Fig.10.3: Current Waveform during Step change in Load

Paralleling of Two Single Unit

Unequal output impedances of parallel operating inverter causes the large amount of circulating current affecting the power sharing capability of inverter. MATLAB Simulink environment was created to observe the impact of load sharing capability. Parallel operated inverter were subjected to following conditions like ineffective control causing loss of synchronization, equal loading, unequal loading with tie-line and single inverter action with forced shut down of operating unit

i) Loss of synchronization:

The ineffective control strategy for sensitive load for varying micro source leads to the collapse of system. Ineffective control schemes drives the parallel operating inverter system out of synchronization leading to loss of power sharing capability of inverter. Forced deviation in magnitude of voltage was created with inefficient control strategy. It was observed that the inverter failed to share the power due to generation of large amount of circulating current. The Fig.(11.1 - 11.4) demonstrates the ineffective power sharing for load of 12 ohms and $12+j0.3768$. The accurate power sharing capability was obtained by implementing the control strategy – Power sharing for equal, unequal loading was observed.

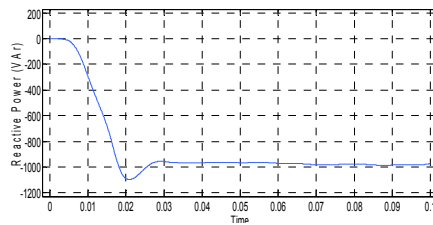

Fig.11.2: Reactive Power loading for Inverter 1

Fig.11.3: Active power loading for Inverter 2

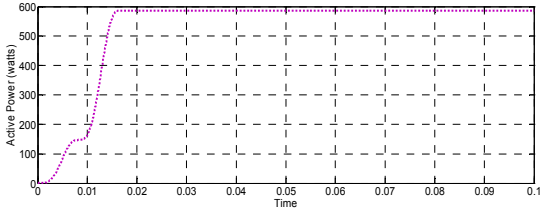

Fig.11.4 :Reactive Power loading for Inverter 2

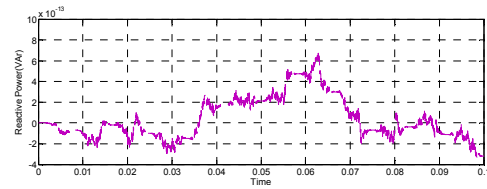

Fig.12.1 Active power loading for Inverter 1

Fig.12.2: Reactive Power loading for Inverter 1

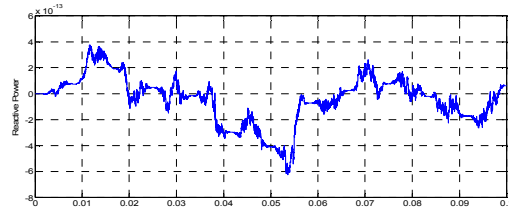
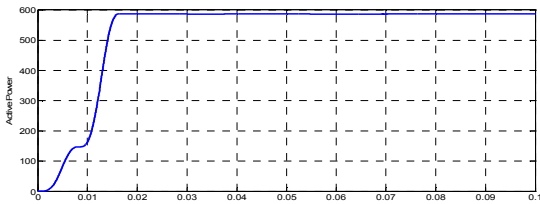

Fig.12.3 :Active power loading for Inverter 2

Fig.12.4: Reactive Power loading for Inverter 2

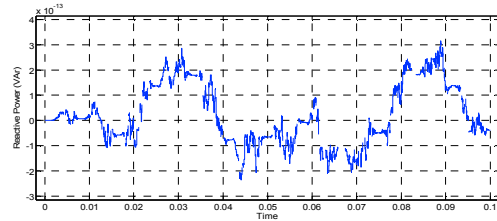
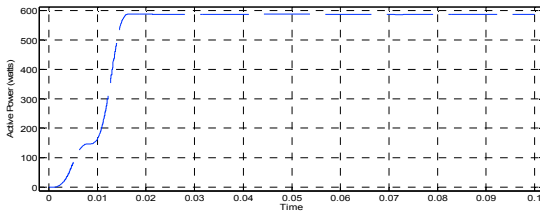

Fig.13.1:Active power loading for Inverter 1

Fig.13.2: Reactive Power loading for Inverter 1

3.1

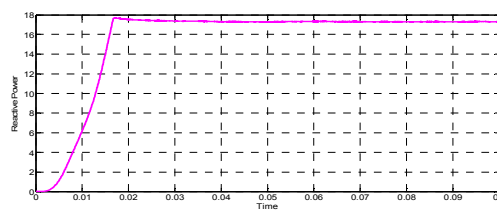
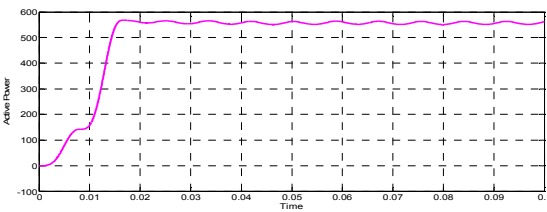

Fig.13.3: Active power loading for Inverter 2

Fig.13.4: Reactive Power loading for Inverter 2

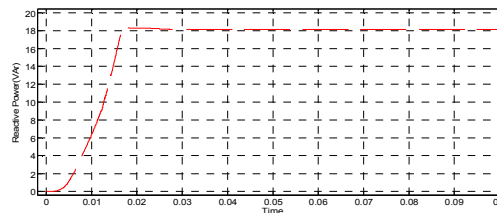
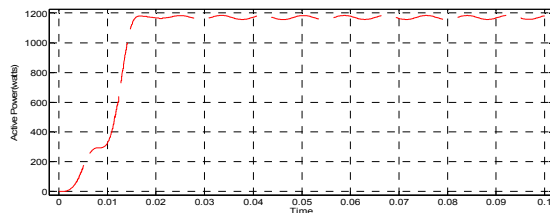

Fig.14.1: Active power loading for Inverter 1

Fig.14.2: Reactive Power loading for Inverter 1

Power Sharing For Equal Load

The wind and solar energy provide the DC link energy to inverter for parallel operation through Power converter system (ac-dc,dc-dc). The inverter systems are operated with equal load sharing of 12 ohms through tie-line as in Fig.(12.1-12.4). Circulating current effect is negligible in equal output impedances. Independent control of individual inverter is obtained with tie-line.

Power Sharing For Unequal Loads

Each inverter is subjected to different load condition. Inverter are operated with Tie-line. Inverter 1 is loaded with resistive load of 12 ohms and inverter 2 with impedance of $12+j0.3768$, $L=1\text{mH}$. Unequal loading produces the circulating current in inverter, tie-line is connected to limit the circulating and to equalize the load impedance. The inverter shares the power in proportional power with tie-line. Fig.(13.1 – 13.4) represents the power shared by inverter 1 and inverter 2

Power Supplied By Inverter With Single Operating Sources

The micro-sources like wind and solar varies constantly, In case of single micro-sources supplying the dc link energy, operating inverter must supply the power for load excess of load. The inverter for such condition must be rated to higher load than actual load. To overcome the problem of power loss the tie-line is avoided. The Fig.(14.1 - 14.2) shows the inverter powering the loads of 12 ohm and $12+j0.3768$.

CONCLUSION

The appropriate power sharing of parallel operating inverter is obtained by limiting the generation of circulating current with the combined effect of current and voltage regulated loop with droop control. The simple control strategy presented in this paper improves the system response with voltage and current regulation incorporating power sharing capability of system. The system uses the simple controller logic with less computation and complexity. The system avoids the communications unit and independent control of each inverter is obtained. The system has better tracking response with simple feedback loops.

REFERENCES

- Josep M. Guerrero, Luis García de Vicuña, José Matas, Miguel Castilla, Jaume Miret, “A Wireless Controller to Enhance Dynamic Performance of Parallel Inverters in Distributed Generation Systems”, *IEEE Trans. On Power Electronics*, Vol. **19**, No. 5, September, 2004.
- Josep M. Guerrero, Luis García de Vicuña, José Matas, Miguel Castilla, Jaume Miret, “Output Impedance Design of Parallel-Connected UPS Inverters With Wireless Load-Sharing Control”, *IEEE Transactions On Industrial Electronics*, Vol. **52**, No. 4, August, 2005
- Josep M. Guerrero, José Matas, Luis García de Vicuña, Miguel Castilla, Jaume Miret, “Decentralized Control for Parallel Operation of Distributed Generation Inverters Using Resistive Output Impedance”, *IEEE Transactions On Industrial Electronics*, Vol. **54**, No. 2, April, 2007
- Yasser Abdel-Rady Ibrahim Mohamed, Ehab F. El-Saadany, “Adaptive Decentralized Droop Controller to Preserve Power Sharing Stability of Paralleled Inverters in Distributed Generation Micro-grids”, *IEEE Transactions on Power Electronics*, Vol. **23**, No. 6, November, 2008
- A. M. Salamah, S.J. Finney, B.W. Williams, “Autonomous controller for improved dynamic performance of AC grid, parallel-connected, single-phase inverters”, *IET Gener. Transm. Distrib.*, Vol. **2-2**, March, 2008
- Yun Wei Li, Ching-Nan Kao, “An Accurate Power Control Strategy for Power-Electronics-Interfaced Distributed Generation Units Operating in a Low-Voltage Multibus Microgrid”, *IEEE Transactions on Power Electronics*, vol. **24**, no. 12, December, 2009

- Amin Hasanzadeh, Omer C. Onar, HosseinMokhtari, AlirezaKhaligh, "A Proportional-Resonant Controller-Based Wireless Control Strategy With a Reduced Number of Sensors for Parallel-Operated UPSs", IEEE Transactions On Power Delivery, Vol. **25**, NO. 1, January,2010.
- Dipankar De, VenkataramananRamanarayanan, "Decentralized Parallel Operation of Inverters Sharing Unbalanced and Nonlinear Loads", IEEE Transactions on Power Electronics, vol. **25**, no. 12, December,2010.
- Mehdi Savaghebi , Josep M. Guerrero, AlirezaJalilian , Juan C. Vasquez , and Tzung-Lin Lee, "Hierarchical Control Scheme for Voltage Harmonics Compensation in an Islanded Droop Controlled Micro-grid" IEEE PEDS 2011, Singapore, 5 - 8 December ,2011
- Qing-Chang Zhong, Yu Zeng "Parallel Operation of Inverters with Different Types of Output Impedance",pp-1398-1403,2013
- George C. Konstantopoulos, Qing-Chang Zhong, BeibeiRen,MiroslavKrstic, "Bounded droop controller for parallel operation of inverters", *Automatica*, Vol.**53** ,pp-320–28,2015
- KoraySenerParlak,MehmetOzdemir, M. TimurAydemir "Active and Reactive Power Sharing and Frequency Restoration in a Distributed Power System Consisting of Two UPS Units"Electrical Power and Energy System,Vol.**31** ,pp-220-26,2009.
- ErnaneAnthioAlves Coelho, PorfirioCabaleiroCortizo, Pedro Francisco Donoso Garcia, "Small Signal Stability For Single Phase Inverter Connected to Stiff AC System", Conference record of 1999 IEEE industrial Application conference Pp- 2180-87,1999.
- A. Tuladhar, H. Jin, T. Unger, K. Mauch,"Parallel Operation of Single Phase Inverter Modules With No Control Interconnections",pp-94-100, 1997
- Naser Abdel Rahim, John E. Quaicoe "Multiple Feedback Loop Control Strategy forSingle-phase Voltage-Source UPS Inverter"ppNo-958-64,1994.
- Dong-Yub Hyun, Chang-Soon Lim, Rae-Young Kim, Dong-Seok Hyun, "Averaged Modeling and Control of a Single-Phase Grid-Connected Two-Stage Inverter for Battery Application", proceeding in 39th annual conference of IECON,Austria, Nov.2013.
- R. D. Middlebrook, Slobodan Cuk, "A General Unified Approach To Modelling Switching-Converter Power Stages", 18-PESC 76 RECORD
- Bommegowda K.B, Vishwas K, Suryanarayana K, N.M.Renukappa, "Single Phase Inverter Control with Capacitor CurrentFeedback", International Conference on Power and Advanced Control Engineering (ICPACE) 2015", pp-418-22,2015
- M. Monfared,"A simplified control strategy for single-phase UPS inverters", *Bulletin Of The Polish Academy Of Sciences Technical Sciences*, Vol. **62**, No. 2, 2014